

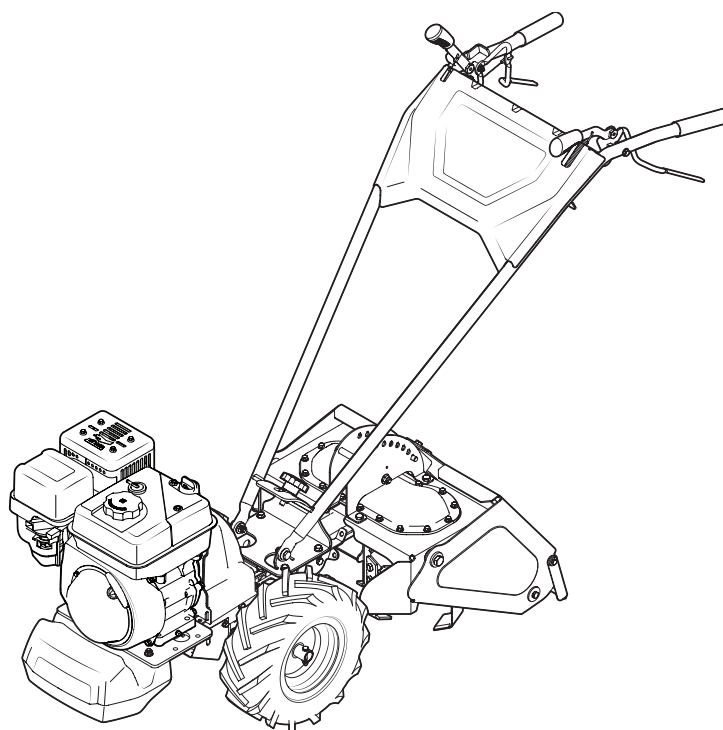

OPERATOR'S MANUAL



Troy-Bilt 700 Series VTT

WARNING

**READ AND FOLLOW ALL SAFETY RULES AND INSTRUCTIONS IN THIS MANUAL
BEFORE ATTEMPTING TO OPERATE THIS MACHINE.
FAILURE TO COMPLY WITH THESE INSTRUCTIONS MAY RESULT IN PERSONAL INJURY.**

TROY-BILT LLC, P.O. BOX 361131 CLEVELAND, OHIO 44136-0019

Thank You

Thank you for purchasing a Troy-Bilt Garden Tiller, It was carefully engineered to provide excellent performance when properly operated and maintained.

Please read this entire manual prior to operating the equipment. It instructs you how to safely and easily set up, operate and maintain your machine. Please be sure that you, and any other persons who will operate the machine, carefully follow the recommended safety practices at all times. Failure to do so could result in personal injury or property damage.

All information in this manual is relative to the most recent product information available at the time of printing. Review this manual frequently to familiarize yourself with the machine, its features and operation. Please be aware that this Operator's Manual may cover a range of product specifications for various models. Characteristics and features discussed and/or illustrated in this manual may not be applicable to all models. We reserve the right to change product specifications, designs and equipment without notice and without incurring obligation.

If applicable, the power testing information used to establish the power rating of the engine equipped on this machine can be found at www.opei.org or the engine manufacturer's web site.

If you have any problems or questions concerning the machine, phone a authorized Troy-Bilt service dealer or contact us directly. Troy-Bilt's Customer Support telephone numbers, website address and mailing address can be found on this page. We want to ensure your complete satisfaction at all times.

Throughout this manual, all references to *right* and *left* side of the machine are observed from the operating position

Table of Contents

Safe Operation Practices	3	Service	15
Assembly & Set-Up	7	Troubleshooting	18
Controls & Features.....	10	Replacement Parts	19
Operation.....	11	Warranty.....	Back Cover
Maintenance & Adjustment	13		

Record Product Information

Before setting up and operating your new equipment, please locate the model plate on the equipment and record the information in the provided area to the right. You can locate the model plate by standing at the operator's position and looking down at the top right corner of the tine shield. This information will be necessary, should you seek technical support via our web site, Customer Support Department, or with a local authorized service dealer.

MODEL NUMBER

--	--	--	--	--	--	--	--	--	--	--

SERIAL NUMBER

--	--	--	--	--	--	--	--	--	--	--

Customer Support

Please do NOT return the machine to the retailer or dealer without first contacting the Customer Support Department.

If you have difficulty assembling this product or have any questions regarding the controls, operation, or maintenance of this machine, you can seek help from the experts. Choose from the options below:

◇ Visit us on the web at www.troybilt.com



See How-to Maintenance and Parts Installation Videos at www.troybilt.com/tutorials

◇ Call a Customer Support Representative at (800) 828-5500 or (330) 558-7220

◇ Write to Troy-Bilt LLC • P.O. Box 361131 • Cleveland, OH • 44136-0019



WARNING! This symbol points out important safety instructions which, if not followed, could endanger the personal safety and/or property of yourself and others. Read and follow all instructions in this manual before attempting to operate this machine. Failure to comply with these instructions may result in personal injury.

When you see this symbol. **HEED ITS WARNING!**

CALIFORNIA PROPOSITION 65



WARNING! Engine Exhaust, some of its constituents, and certain vehicle components contain or emit chemicals known to State of California to cause cancer and birth defects or other reproductive harm.



WARNING! Battery posts, terminals, and related accessories contain lead and lead compounds, chemicals known to the State of California to cause cancer and reproductive harm. *Wash hands after handling*



DANGER! This machine was built to be operated according to the safe operation practices in this manual. As with any type of power equipment, carelessness or error on the part of the operator can result in serious injury. This machine is capable of amputating fingers, hands, toes and feet. Failure to observe the following safety instructions could result in serious injury or death.

Training

1. Read, understand, and follow all instructions on the machine and in the manual(s) before attempting to assemble and operate. Keep this manual in a safe place for future and regular reference and for ordering replacement parts.
2. Be familiar with all controls and their proper operation. Know how to stop the machine and disengage them quickly.
3. Never allow children under 14 years of age to operate this machine. Children 14 and over should read and understand the instructions and safe operation practices in this manual and on the machine and be trained and supervised by an adult.
4. Never allow adults to operate this machine without proper instruction.
5. Keep the area of operation clear of all persons, particularly small children and pets. Stop machine if anyone enters the area.
2. Wear sturdy, rough-soled work shoes and close fitting slacks and shirt. Loose fitting clothes or jewelry can be caught in moving parts. Never operate this machine in bare feet or sandals.
3. Disengage clutch levers and shift (if provided) into neutral ("N") before starting the engine.
4. Never leave this machine unattended with the engine running.
5. Never attempt to make any adjustments while engine is running, except where specifically recommended in the operator's manual.

Safe Handling of Gasoline:

To avoid personal injury or property damage use extreme care in handling gasoline. Gasoline is extremely flammable and the vapors are explosive. Serious personal injury can occur when gasoline is spilled on yourself or your clothes which can ignite. Wash your skin and change clothes immediately.

- a. Use only an approved gasoline container.
- b. Never fill containers inside a vehicle or on a truck or trailer bed with a plastic liner. Always place containers on the ground away from your vehicle before filling.

Preparation

1. Thoroughly inspect the area where the equipment is to be used. Remove all stones, sticks, wire, and other foreign objects which could be tripped over and cause personal injury.

- c. When practical, remove gas-powered equipment from the truck or trailer and refuel it on the ground. If this is not possible, then refuel such equipment on a trailer with a portable container, rather than from a gasoline dispenser nozzle.
 - d. Keep the nozzle in contact with the rim of the fuel tank or container opening at all times until fueling is complete. Do not use a nozzle lock-open device.
 - e. Extinguish all cigarettes, cigars, pipes and other sources of ignition.
 - f. Never fuel machine indoors.
 - g. Never remove gas cap or add fuel while the engine is hot or running. Allow engine to cool at least two minutes before refueling.
 - h. Never over fill fuel tank. Fill tank to no more than ½ inch below bottom of filler neck to allow space for fuel expansion.
 - i. Replace gasoline cap and tighten securely.
 - j. If gasoline is spilled, wipe it off the engine and equipment. Move unit to another area. Wait 5 minutes before starting the engine.
 - k. To reduce fire hazards, keep machine free of grass, leaves, or other debris build-up. Clean up oil or fuel spillage and remove any fuel soaked debris.
 - l. Never store the machine or fuel container inside where there is an open flame, spark or pilot light as on a water heater, space heater, furnace, clothes dryer or other gas appliances.
- 11. After striking a foreign object, stop the engine, disconnect the spark plug wire and ground against the engine. Thoroughly inspect the machine for any damage. Repair the damage before starting and operating.
 - 12. Disengage all clutch levers (if fitted) and stop engine before you leave the operating position (behind the handles). Wait until the tines come to a complete stop before unclogging the tines, making any adjustments, or inspections.
 - 13. Never run an engine indoors or in a poorly ventilated area. Engine exhaust contains carbon monoxide, an odorless and deadly gas.
 - 14. Muffler and engine become hot and can cause a burn. Do not touch.
 - 15. Use caution when tilling near fences, buildings and underground utilities. Rotating tines can cause property damage or personal injury.
 - 16. Do not overload machine capacity by attempting to till soil too deep at too fast of a rate.
 - 17. If the machine should start making an unusual noise or vibration, stop the engine, disconnect the spark plug wire and ground it against the engine. Inspect thoroughly for damage. Repair any damage before starting and operating.
 - 18. Keep all shields, guards, and safety devices in place and operating properly.
 - 19. Never pick up or carry machine while the engine is running.
 - 20. Use only attachments and accessories approved by the manufacturer. Failure to do so can result in personal injury.
 - 21. If situations occur which are not covered in this manual, use care and good judgement. Contact Customer Support for assistance and the name of you nearest servicing dealer..

Operation

1. Do not put hands or feet near rotating parts. Contact with the rotating parts can amputate hands and feet.
2. Do not operate machine while under the influence of alcohol or drugs.
3. Never operate this machine without good visibility or light. Always be sure of your footing and keep a firm hold on the handles.
4. Keep bystanders away from the machine while it is in operation. Stop the machine if anyone enters the area.
5. Be careful when tilling in hard ground. The tines may catch in the ground and propel the tiller forward. If this occurs, let go of the handle bars and do not restrain the machine.
6. Exercise extreme caution when operating on or crossing gravel surfaces. Stay alert for hidden hazards or traffic. Do not carry passengers.
7. Never operate the machine at high transport speeds on hard or slippery surfaces.
8. Exercise caution to avoid slipping or falling.
9. Look down and behind and use care when in reverse or pulling machine towards you.
10. Start the engine according to the instructions found in this manual and keep feet well away from the tines at all times.

Maintenance & Storage

1. Keep machine, attachments and accessories in safe working order.
2. Allow a machine to cool at least five minutes before storing. Never tamper with safety devices. Check their proper operation regularly.
3. Check bolts and screws for proper tightness at frequent intervals to keep the machine in safe working condition. Also, visually inspect machine for any damage.
4. Before cleaning, repairing, or inspecting, stop the engine and make certain the tines and all moving parts have stopped. Disconnect the spark plug wire and ground it against the engine to prevent unintended starting.
5. Do not change the engine governor settings or over-speed the engine. The governor controls the maximum safe operating speed of engine.
6. Maintain or replace safety and instruction labels, as necessary.
7. Follow this manual for safe loading, unloading, transporting, and storage of this machine.
8. Always refer to the operator's manual for important details if the machine is to be stored for an extended period.

9. If the fuel tank has to be drained, do this outdoors.
10. Observe proper disposal laws and regulations for gas, oil, etc. to protect the environment.
11. According to the Consumer Products Safety Commission (CPSC) and the U.S. Environmental Protection Agency (EPA), this product has an *Average Useful Life* of seven (7) years, or 130 hours of operation. At the end of the *Average Useful Life* have the machine inspected annually by an authorized service dealer to ensure that all mechanical and safety systems are working properly and not worn excessively. Failure to do so can result in accidents, injuries or death.

Notice Regarding Emissions

Engines which are certified to comply with California and federal EPA emission regulations for SORE (Small Off Road Equipment) are certified to operate on regular unleaded gasoline, and may include the following emission control systems: Engine Modification (EM), Oxidizing Catalyst (OC), Secondary Air Injection (SAI) and Three Way Catalyst (TWC) if so equipped.

Spark Arrestor









WARNING! This machine is equipped with an internal combustion engine and should not be used on or near any unimproved forest-covered, brushcovered or grass-covered land unless the engine's exhaust system is equipped with a spark arrestor meeting applicable local or state laws (if any).

If a spark arrestor is used, it should be maintained in effective working order by the operator. In the State of California the above is required by law (Section 4442 of the California Public Resources Code). Other states may have similar laws. Federal laws apply on federal lands.

A spark arrestor for the muffler is available through your nearest engine authorized service dealer or contact the service department, P.O. Box 361131 Cleveland, Ohio 44136-0019.

Safety Symbols

This page depicts and describes safety symbols that may appear on this product. Read, understand, and follow all instructions on the machine before attempting to assemble and operate.

Symbol	Description
	READ THE OPERATOR'S MANUAL(S) Read, understand, and follow all instructions in the manual(s) before attempting to assemble and operate.
	WARNING— ROTATING TINES Do not put hands or feet near rotating parts. Contact with the rotating parts can amputate hands and feet.
	WARNING— ROTATING TINES Do not put hands or feet near rotating parts. Contact with the rotating parts can amputate hands and feet.
	WARNING— GASOLINE IS FLAMMABLE Allow the engine to cool at least two minutes before refueling.
	WARNING— CARBON MONOXIDE Never run an engine indoors or in a poorly ventilated area. Engine exhaust contains carbon monoxide, an odorless and deadly gas.
	WARNING— HOT SURFACE Engine parts, especially the muffler, become extremely hot during operation. Allow engine and muffler to cool before touching.



WARNING! Your Responsibility—Restrict the use of this power machine to persons who read, understand and follow the warnings and instructions in this manual and on the machine.

SAVE THESE INSTRUCTIONS!

Contents of Carton

- One Tiller
- One Hardware Pack
- One Handlebar Assembly
- One Operator's Manual
- One Bottle Oil
- One Engine Operator's Manual



WARNING! To prevent personal injury or property damage, do not start the engine until all assembly steps are complete and you have read and understand the safety and operating instructions.

Recommended Tools for Assembly

- Two ½" open-ended wrenches or sockets
- Scissors (to trim plastic ties)
- Tire pressure gauge
- Clean oil funnel
- Included bottle of oil

Contents of Hardware pack

- ⅝-18 Hex Lock Nut (2)
- ⅝-18 x .437 x .268 Shoulder Screw (2)
- .349 x .879 x .063 Flat Washer (2)
- .450 x 1.000 x .062 Belleville Washer (2)

Assembly

Unpacking Instructions

1. Remove any cardboard inserts and packaging material from the carton. Remove any staples from the bottom of the carton and remove the carton.
2. Cut the large, plastic tie strap that secures the transmission tube to the shipping pallet. Leave the handlebars on top of the tiller to avoid damaging any cables.
3. The hardware bag is inside the literature envelope. Check the contents with the list above.
4. The tiller is heavy. You should not attempt to remove it from the shipping platform until instructed to do so in these steps.

Handle

1. Remove the handle by cutting any zip-ties that secure it to the tiller frame.
2. Remove the star knob from the handle mount bracket. See Figure 3-1.

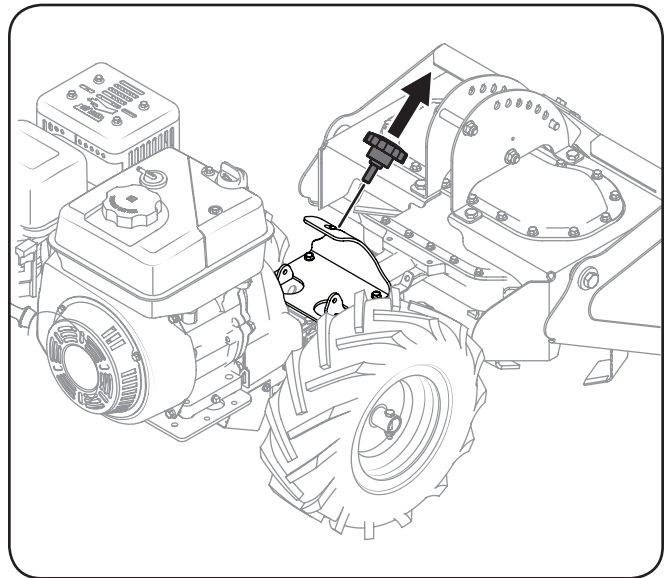

Figure 3-1

3. Using the shoulder screws, hex lock nuts, flat washers and Belleville washers from the hardware pack, mount the handle to the handle mount plate as shown in Figure 3-2.

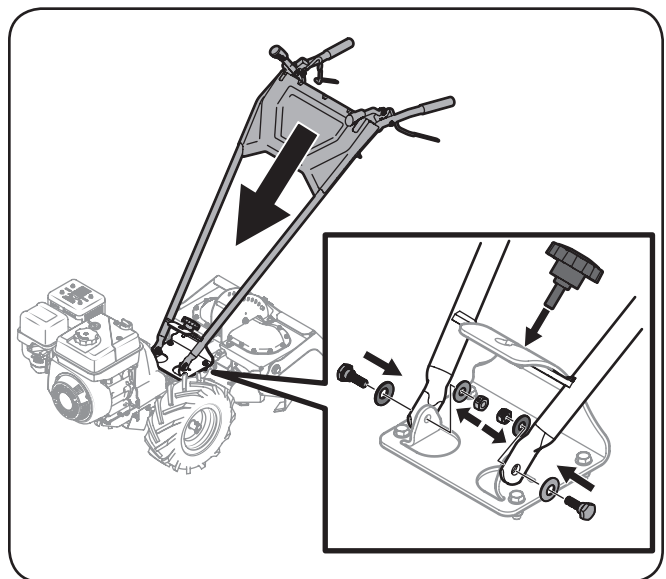

Figure 3-2

4. Gently lift the handlebar and place the handlebar brace in the desired height position on the handle mount bracket and secure it in place with the star knob removed in Step 2. See Figure 3-2.
5. Locate the forward (black) and reverse (red) cables on the right side of the handle. Remove any packaging material or ties on the cables being sure not to damage them.
6. The forward (black) cable is routed up the back of the right handle and snapped into the cable mount bracket as shown in Figure 3-3.

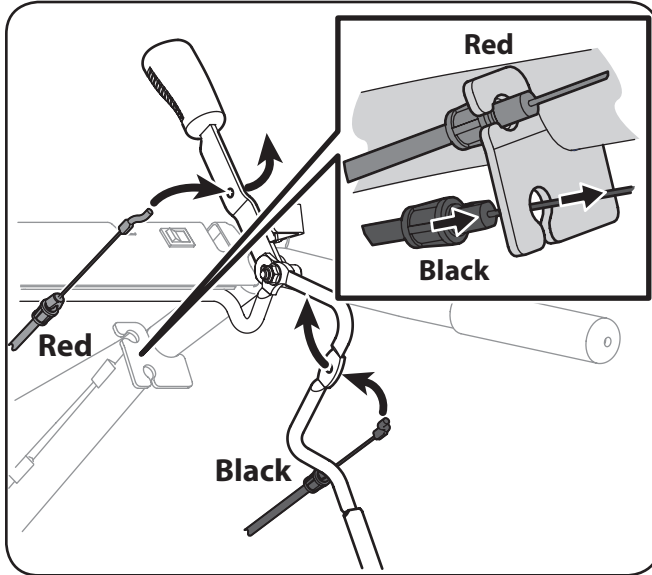

Figure 3-3

7. When the forward (black) cable is correctly mounted on the cable mount bracket, install the z-fitting into the clutch bail. See Figure 3-3.
8. The reverse (red) cable is routed up the right side of the right handle and snapped into the cable mount bracket as shown in Figure 3-3.
9. When the reverse (red) cable is correctly mounted on the cable mount bracket, feed the cable through the slot in the panel and then connect the z-fitting into the reverse handle. See Figure 3-3.

10. Route the wire harness up the back of the handle and connect the harness to the ON/OFF switch on the underside of the panel. See Figure 3-4.

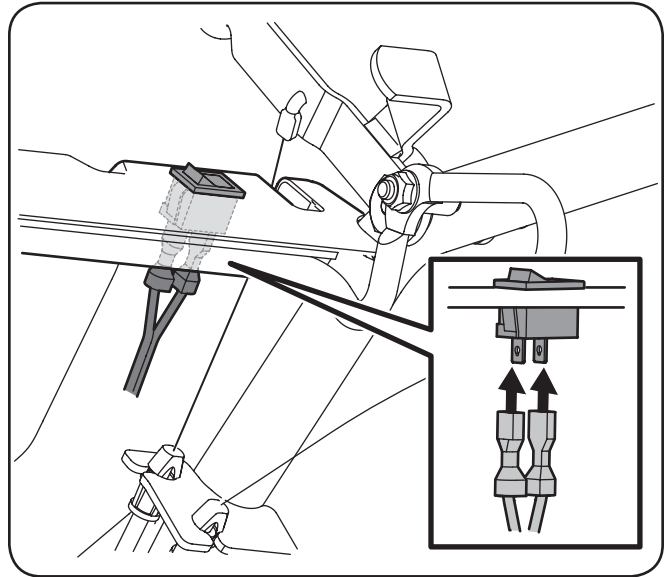

Figure 3-4

11. Route the tine engagement cable up the left handle, through the slot in the panel and hook it into the tine engagement handle. See Figure 3-5.

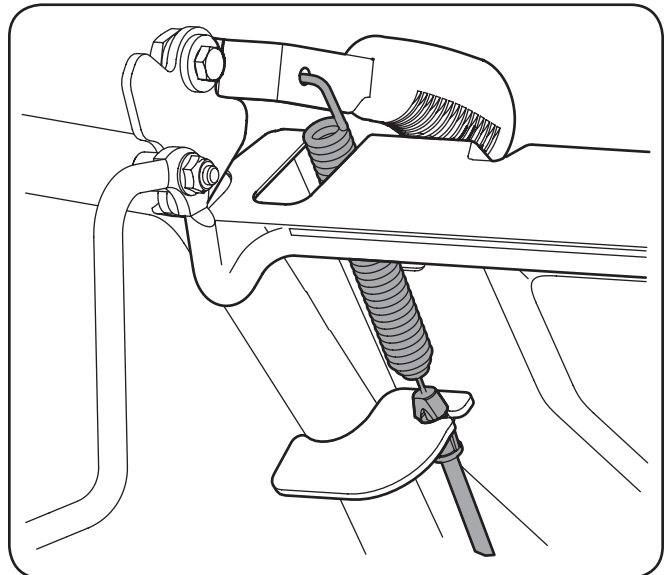

Figure 3-5

12. When the cable is properly hooked into the handle, snap it into the cable mount bracket as shown in Figure 3-5.

- Secure the wires and cables to the handles by using the two cable ties from the hardware pack as shown in Figure 3-6.

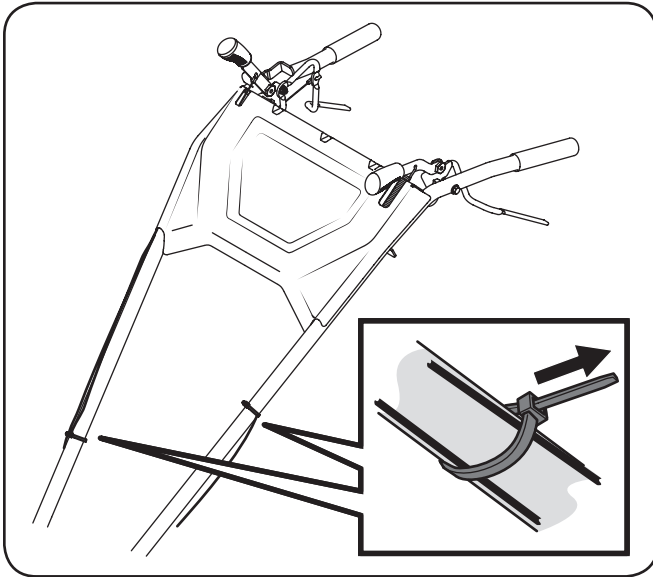

Figure 3-6

- Place the neutral handle into free wheel position and roll the tiller off the crate. See the Operation section for more information on placing the tiller in the free wheel position.

Set-Up

Handle

The handle should be adjusted so that when the tiller is digging 3-4" into the soil, the handle falls to about waste-high. star knob, move the handle to the desired position and then lock into place by tightening the star knob to secure the handle. See Figure 3-7.

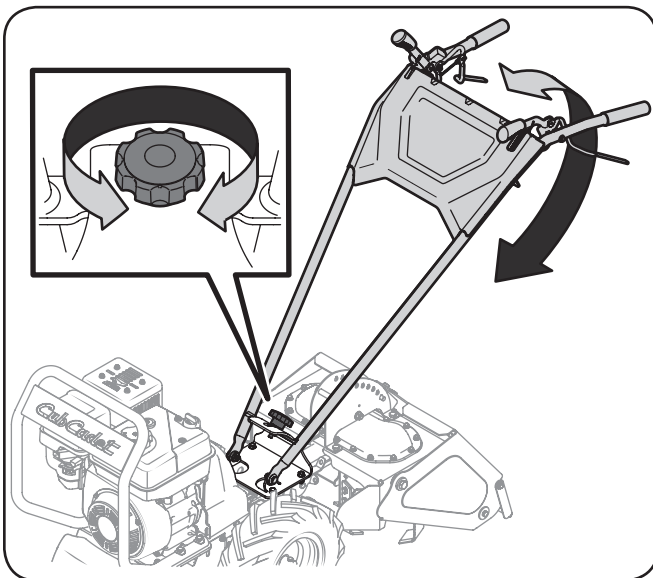

Figure 3-7

Tire Pressure

Check the air pressure with a tire gauge. Deflate or inflate the tires equally to between 15 and 20 PSI. DO NOT EXCEED 20 P.S.I.

NOTE: Be sure that both tires are inflated equally or the tiller will pull to one side.

Gas & Oil Fill-Up

Service the engine with gasoline and oil as instructed in the separate Engine Operator's Manual packed with your tiller. Read the instructions carefully.



WARNING! Use extreme care when handling gasoline. Gasoline is extremely flammable and the vapors are explosive. Never fuel the machine indoors or while the engine is hot or running.

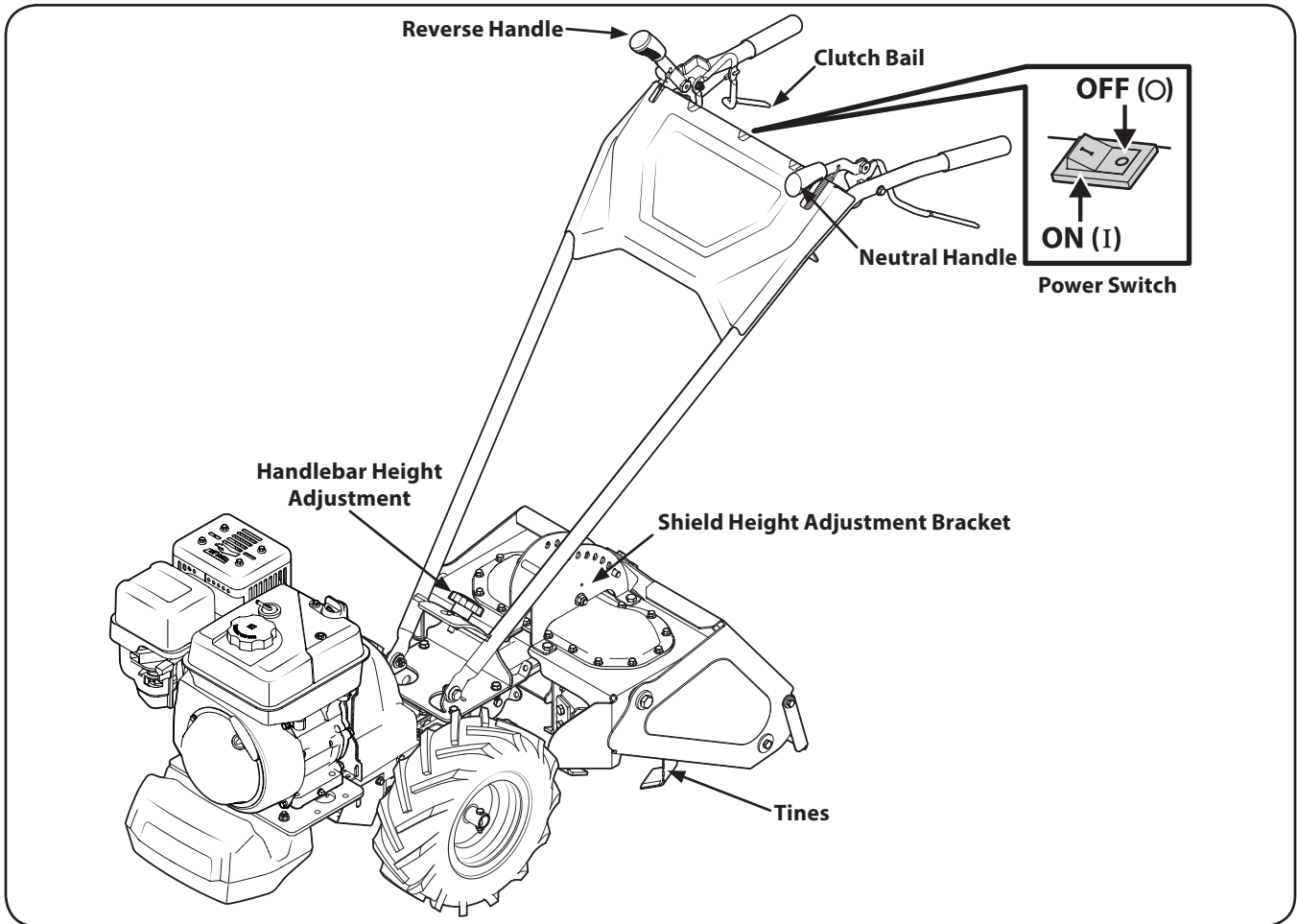

Engine Controls

See the separate Engine Operator's Manual for information and functions of the engine controls.

Shield Height Adjustment Bracket

The shield height adjustment bracket is used to set the tilling depth. To change the tilling depth remove the depth pin from the bracket and lift up on the handle. Place the depth pin in the desired hole and carefully lower the handle.

Handlebar Height Adjustment

The handlebar height adjustment is located in front of the tine shield between the lower arms of the handles. The handle can be placed in three different positions. To adjust the handle, loosen the star knob, move the handle into one of the three available positions and retighten the star knob to secure it into place.

Power Switch

The power switch is located on the right side of the panel. It is used to stop the tiller/engine and must be in the ON position to start the engine.



Neutral Handle

The neutral handle is located on the upper left handle. When the neutral handle is in the forward (disengaged) position the tiller is in neutral and the wheels are in "free wheel." To engage the wheels (forward or reverse), pull the neutral handle rearward into the engaged position. The neutral handle will remain in the engaged position until it is moved back into the free wheel position.

Reverse Handle

The reverse handle is located on the upper right handle. When the reverse handle is pulled back into the reverse position, the tines and wheels (if the the neutral handle is engaged) will move in reverse. To activate the reverse movement of the tines only, engage the reverse handle with the neutral handle in the free wheel position. When the reverse handle is released, it will return to the forward (disengaged) position and the tines and wheels will stop moving.

Clutch Bail

The clutch bail is located below the handles. When the clutch bail is in the disengaged position the tines will not rotate. When the clutch bail is pulled upward against the handles in the engaged position, the tines are engaged and will rotate forward until the engine is stopped or the clutch bail is released. When the neutral handle is also in the engaged position, this will allow the tines and wheels to move forward.

Starting the Tiller

Pre-Start Checklist

With the spark plug wire disconnected from the spark plug, make the following checks and perform the following services before starting the engine.

1. Read the Safe Operation Practices and Controls & Features Sections in this manual. Read the separate Engine Operator's Manual.
2. Check the machine for loose or missing hardware. Service as required.
3. Check the engine oil level. See Engine Operator's Manual.
4. Check that all the safety guards and covers are in place.
5. Check air cleaner and engine cooling system. See Engine Operator's Manual.
6. Attach the spark plug wire to the spark plug.
7. Fill the fuel tank with gasoline according to the directions in the separate Engine Operator's Manual. Follow all the instructions and safety rules carefully.



WARNING! Never run the engine indoors or in enclosed, poorly ventilated areas. Engine exhaust contains carbon monoxide, an odorless and deadly gas. Avoid the engine muffler and nearby areas. Temperatures in these areas may exceed 150° F.

Starting the Engine

1. Complete the "Pre-Start Checklist."
2. Disengage the tines.
3. Flip the power switch into the ON position,
4. Proceed with the engine starting instructions in your Engine Operator's Manual.

Stopping the Tiller

1. To stop the wheels and tines, release the forward clutch bail or the reverse handle (whichever control is engaged) and place the tine engagement handle in the disengaged position.
2. To stop the engine place the power switch in the OFF position and follow the instructions in your Engine Operator's Manual.

Setting the Depth

To set the tilling depth, remove the depth pin from the shield height adjustment bracket, move the tine shield into the desired position and re-insert the depth pin. See Figure 5-1.

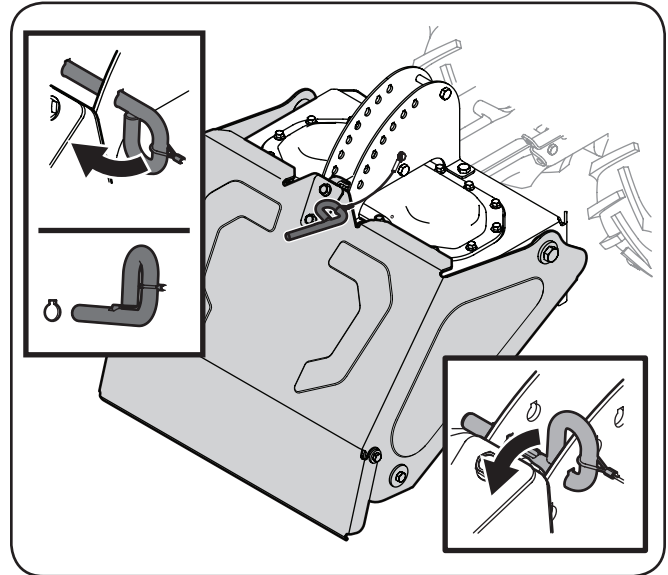

Figure 5-1

NOTE: The depth pin is keyed and will need to be turned to remove and install into the shield height adjustment bracket.

Engaging the Drive & Tines

1. For forward motion of the tines:
 - a. Pull the clutch control bail up with the neutral handle in the free wheel position, the reverse handle disengaged and hold it against the handlebars. See Figure 5-2. To stop the forward motion of the tines, release the bail.

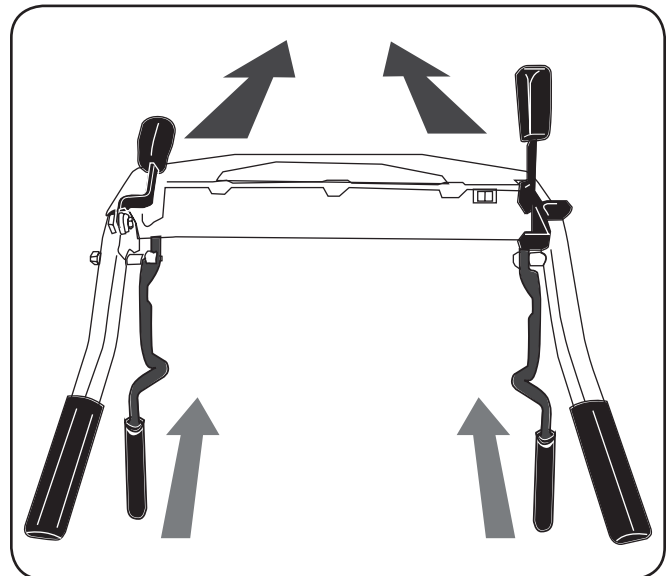

Figure 5-2

2. For forward motion of the tines and wheels:
 - a. Engage the neutral handle and the clutch control bail, with the reverse handle disengaged and the tines and wheels will move forward. See Figure 5-3. To stop the forward motion of the tines and wheels, release the bail.

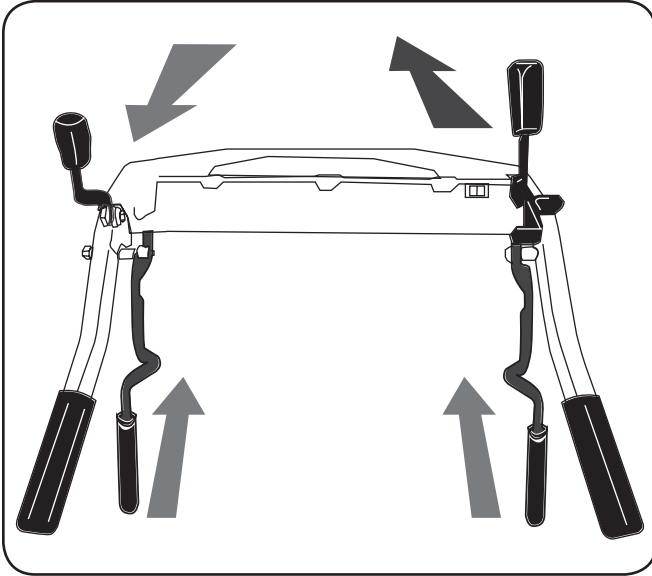

Figure 5-3

2. For reverse motion of the tines and wheels:
 - a. Engage the neutral handle and the reverse handle, with the clutch control bail disengaged and the tines and wheels will move in reverse. See Figure 5-5. To stop the reverse motion of the tines and wheels, release the reverse handle.

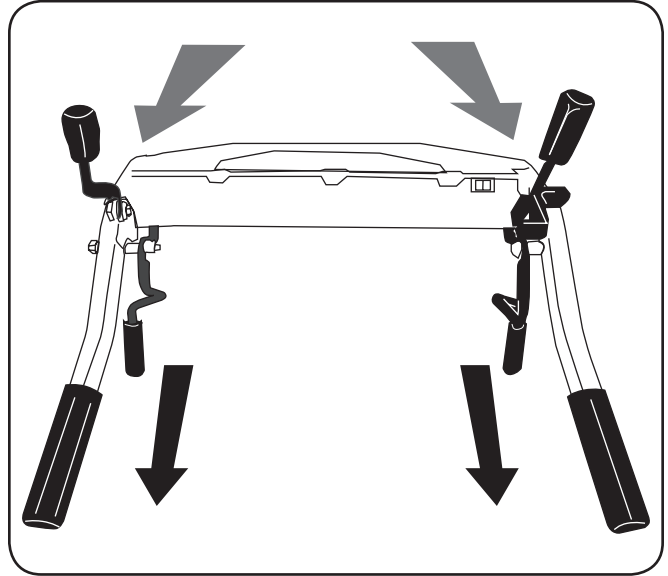

Figure 5-5

3. For reverse motion of the tines:
 - a. Pull the reverse handle back with the neutral handle in the free wheel position and the clutch control bail disengaged to reverse the tines. See Figure 5-4. To stop the reverse motion of the tines, release the reverse handle.

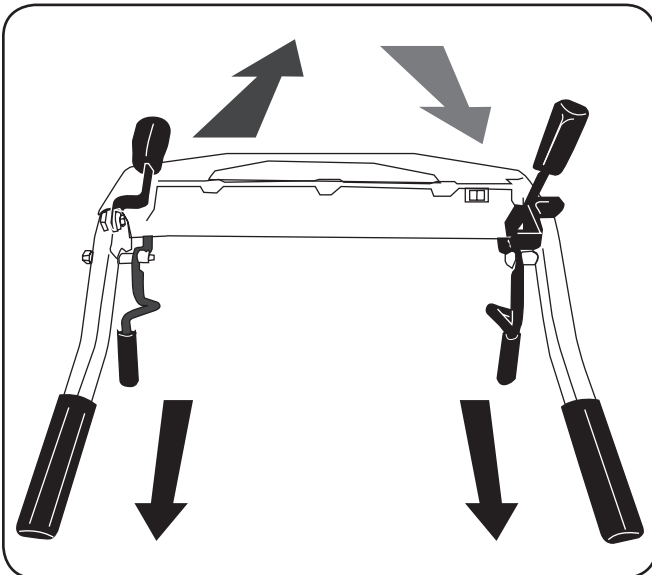

Figure 5-4

Maintenance Schedule

	Check After First 2 Hours	Before Each Use	Every 5 Hours	Every 10 Hours	Every 30 Hours
Clean Engine		✓			
Check Drive Belt Tension	✓			✓	
Check Nuts and Bolts	✓			✓	
Lubricate Tiller				✓	
Check Gear Oil Level in Transmission					✓
Check Tines for Wear					✓
Check Air Pressure in Tires					✓



WARNING! Before inspecting, cleaning or servicing the machine, shut off the engine, wait for all moving parts to come to a complete stop, disconnect the spark plug wire and move the wire away from the spark plug. Failure to follow these instructions can result in serious personal injury or property damage.

2. With the tiller on level ground, place the depth pin in the highest position.
3. Remove the oil fill plug from the transmission housing and look inside the oil fill hole to locate the main drive shaft situated below the hole. See Figure 6-1.

Maintenance

Engine

Refer to the Engine Operator's Manual for all engine maintenance.

Tire Pressure

Check the air pressure in both tires. The air pressure should be between 15-20 PSI. Keep both tires equally inflated to help prevent machine from pulling to one side.

Hardware

Check for loose or missing hardware after every 10 operating hours and tighten or replace — as needed — before reusing the tiller

Be sure to check the screws underneath the tiller hood that secure the transmission cover and the Depth Regulator Lever to the transmission.

Transmission Gear Oil

Check the transmission gear oil after every 30 hours of operation or whenever you notice any oil leak. Operating the tiller when the transmission is low on oil can result in severe damage.

To Check the Transmission Gear Oil Level:

1. Check the gear oil level when the transmission is cool. Gear oil will expand in warm operating temperatures and this expansion will provide an incorrect oil level reading.

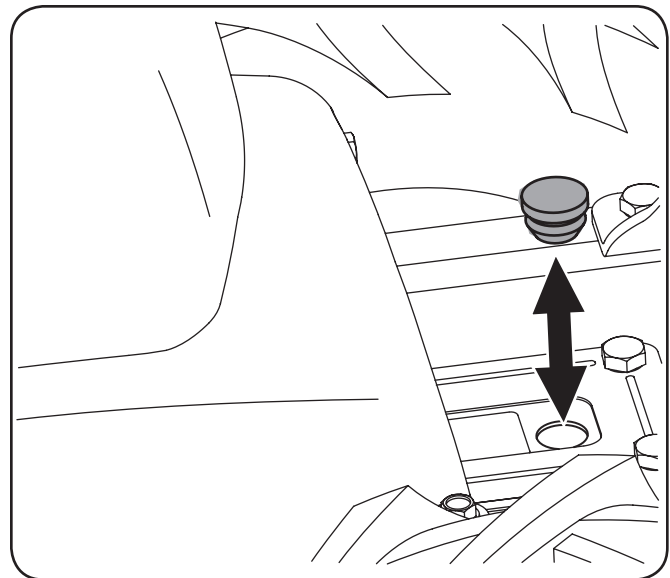

Figure 6-1

4. The gear oil level is correct if the gear oil is approximately halfway up the side of the main drive shaft.
5. If the gear oil level is low, add gear oil as described next. If the gear oil level is okay, securely replace the oil fill plug.

6. If adding only a few ounces of gear oil, use API rated GL-4 or GL-5 gear oil having a viscosity of SAE 140, SAE 85W-140 or SAE 80W-90. If refilling an empty transmission, use only GL-4 gear oil having a viscosity of SAE 85W-140 or SAE 140.
7. While checking frequently to avoid overfilling, slowly add gear oil into the oil fill hole until it reaches the halfway point on the drive shaft.
8. Securely replace the oil fill plug.

Lubrication

After every 10 operating hours, oil or grease the lubrication described below. Use clean lubricating oil (#30 weight motor oil is suitable) and clean general purpose grease (grease containing a metal lubricant is preferred, if available).

- Remove the wheels, clean the wheel shaft and apply a thin coating of grease.
- Grease the back, front and sides of the depth regulator lever.
- Remove the tines and clean the tine shaft. Use a file or sandpaper to gently remove any rust, burrs or rough spots (especially around the holes in the shaft). Apply grease to the ends of the shaft before installing the tines.
- Oil the threads on the handlebar height adjustment screws and the handlebar attaching screws.

Off-Season Storage

When the tiller won't be used for an extended period, prepare it for storage as follows:

1. Clean the tiller and engine.
2. Do routine tiller lubrication and check for loose parts and hardware.
3. Service the engine as instructed in the separate engine manual.
4. Engines stored between 30 and 90 days need to be treated with a gasoline stabilizer such as **STA-BIL**® and engines stored over 90 days need to be drained of fuel to prevent deterioration and gum from forming in fuel system or on essential carburetor parts. If the gasoline in your engine deteriorates during storage, you may need to have the carburetor, and other fuel system components, serviced or replaced.



WARNING: Drain fuel only into an approved container outdoors, away from an open flame. Allow engine to cool. Extinguish cigarettes, cigars, pipes, and other sources of ignition prior to draining fuel.

5. Store the tiller in a clean, dry area.
6. Never store the tiller with fuel in the fuel tank in an enclosed area where gas fumes could reach an open flame or spark, or where ignition sources are present (space heaters, hot water heaters, furnaces, etc.).

Belt Replacement

If the drive belt need to be replaced, it is best to replace both belts at the same time. Use only a factory-authorized belt as an "over-the-counter" belt may not perform satisfactorily. The procedure requires average mechanical ability and commonly available tools.

To replace the Drive and Reverse belts, follow these steps:

1. Make sure the tiller is on a flat surface, with the engine turned off and the spark plug wire unplugged and grounded to prevent unintended firing of the engine.
2. Remove the belt cover as seen in "Figure 7-1", by first removing the two ¼-20 hex washer screws and one flat washer. Lift the belt cover up and away from the tiller and set in a safe location until reinstallation.

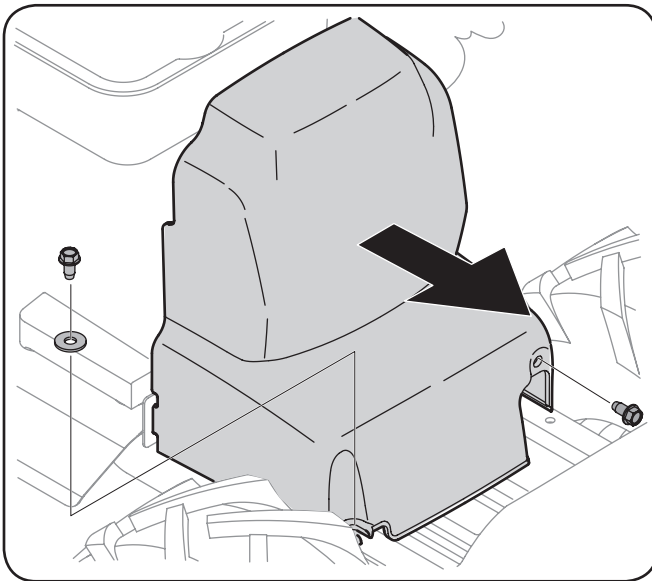

Figure 7-1

3. Remove the four hex washer screws that secure the pulley shield to the frame as seen in "Figure 7-2", and remove the pulley shield and set aside in a safe location until reinstallation.

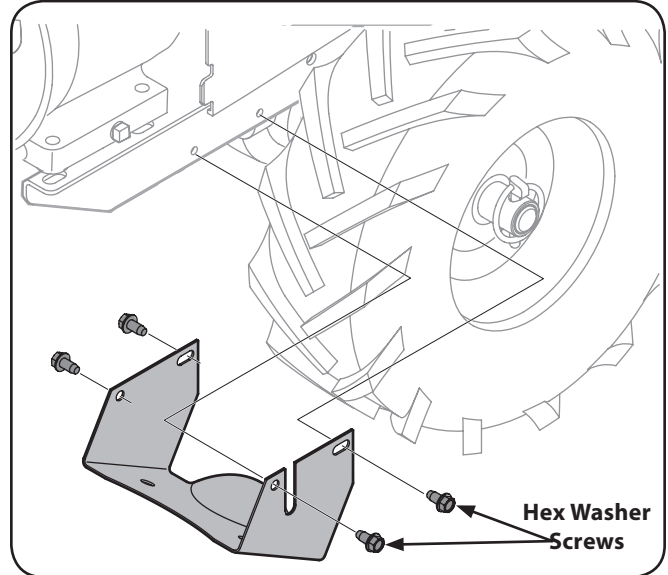

Figure 7-2

4. Remove the idler bracket extension spring, as pointed out in "Figure 7-3". It is recommended to use a pair of needle-nosed pliers, and grab the spring by the end that hooks over the frame. Simply grab it and pull it away from the frame, then up wards and carefully relieve the tension of the spring.

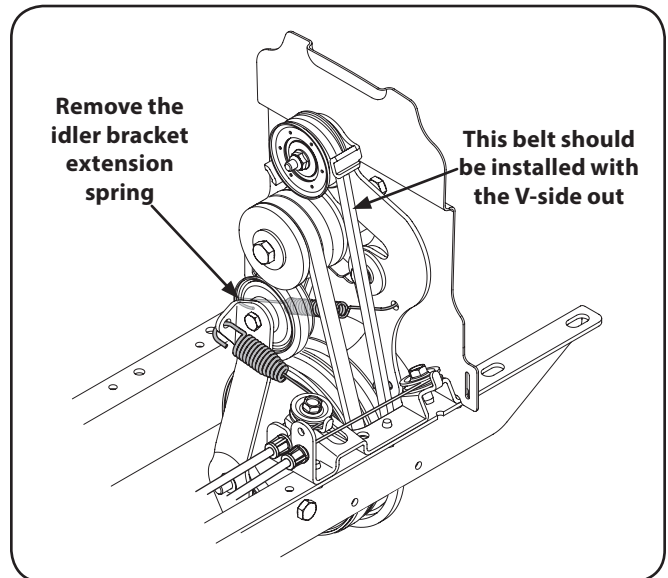

Figure 7-3

- Remove the idler pulley bracket by removing the 5/16-24 hex screw, flat washer and lock washer, as in "Figure 7-4".

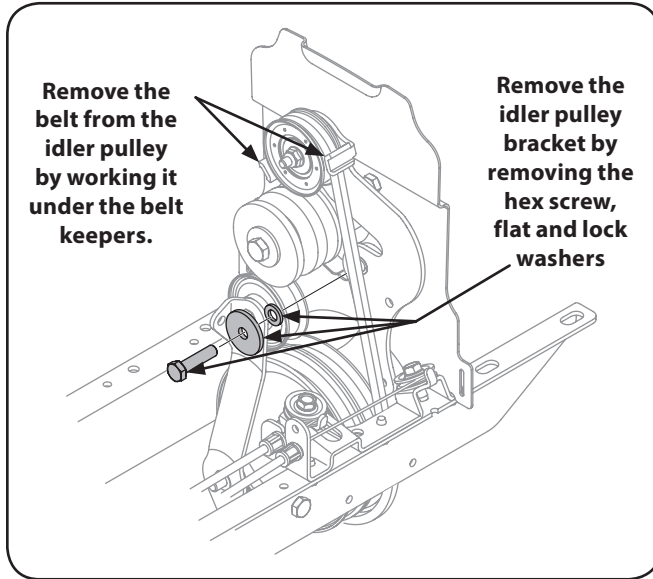

Figure 7-4

NOTE: It will be necessary to remove the belt from around the idler pulley by working it off the pulley and from underneath each belt keeper.

- Remove the flange nut securing the transmission drive pulley, then remove the pulley along with the two belts. See "Figure 7-5".

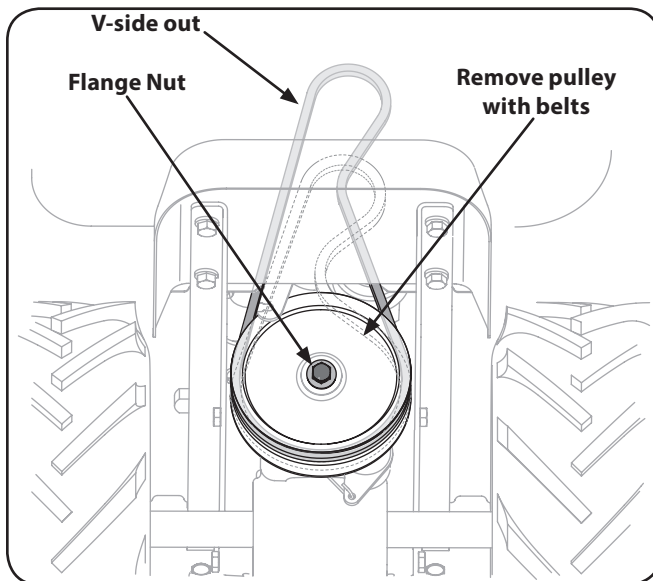

Figure 7-5

- Replace the old belts with the new belts in the same order they were removed. The longer belt (954-04091) belongs closer to the engine (V-side out), with the shorter belt (954-05069) positioned closer to the tines.

- Reinstall the transmission drive pulley with the new belts.
- Reassemble the tiller in the reverse order in which it was disassembled.

NOTE: When reinstalling the belt cover, be sure to engage the bail and hold it so that the drive belt is tight before attempting to reinstall the belt cover. This will enable the belt to fall under the belt keeping mechanism built into the belt cover. Failure to do so could damage the belt and/or belt cover.

Tines

The tines will wear with use and should be inspected at the beginning of each tilling season and after every 30 operating hours. The tines can be replaced. Refer to the Illustrated Parts List manual for part numbers and ordering instructions.

Tine Inspection

With use, the tines will become shorter, narrower and pointed. Badly worn tines will result in a loss of tilling depth, and reduced effectiveness when chopping up and turning under organic matter.

Removing/Installing a Tine Assembly & Tines

- Remove the tine shield by removing the hex lock screw and flat washers securing it to the transmission on each side.
- A tine assembly consists of a tine bracket and three tines. There are two tine assemblies on the tiller a RH assembly (Part No. 642-05032) and a LH assembly (642-05033).
NOTE: Marking the tines and taking note of the different RH and LH assemblies will make re-installing the assemblies properly easier.
- To remove a tine assembly, simply remove the hex screw and flange lock nut as seen in "Figure 7-6". Remove the hex screw and slide the assembly off the tine shaft.

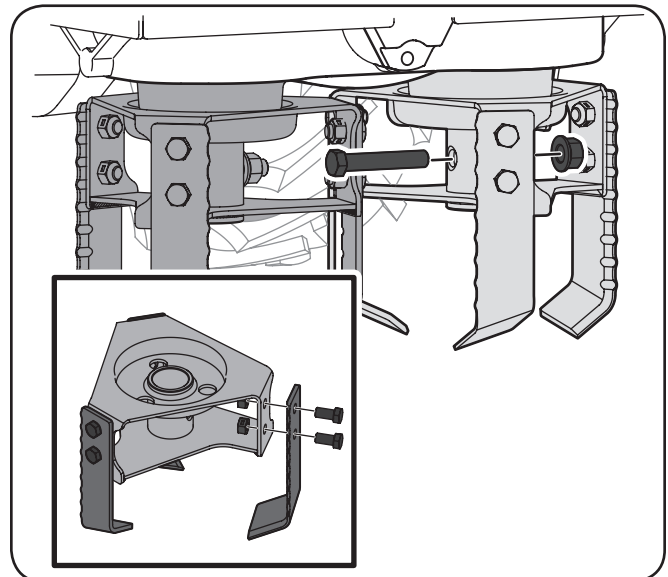

Figure 7-6

- Before reinstalling the tine assembly, inspect the tine shaft for rust, rough spots or burrs. Lightly file or sand, as needed. Apply a thin coat of grease to the shaft.

5. Install the tine assemblies on the proper tine shaft using the hex screw and flange lock nut as seen in "Figure 7-6".
6. To remove an individual tine from the assembly, remove the tine assembly as instructed above and remove the individual tine by removing the hex screw and hex lock nut that secure it to the assembly.



NOTE: Like the assemblies, there are specific tines for both the RH (Part No. 742-05076) and LH (742-05091) assemblies. Be certain the tine is the same as the others on the assembly.

Change Transmission Gear Oil

NOTE: The transmission gear oil does not need to be changed unless it has been contaminated with dirt, sand or metal particles.

See an authorized service dealer to have the transmission gear oil changed. Refer to the phone numbers on page 2 of this manual to locate the nearest service dealer.

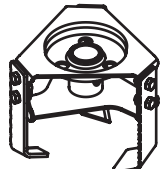
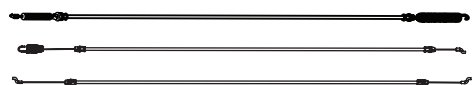
Problem	Cause	Remedy
Tines do not engage	<ol style="list-style-type: none">1. Foreign object lodged in tines.2. Tine hardware missing.3. Pulley and idler not in correct adjustment.4. Belt worn and/or stretched.	<ol style="list-style-type: none">1. Dislodge foreign object.2. Replace tine hardware.3. Take tiller to authorized service dealer.4. Replace belt.
Wheels do not engage	<ol style="list-style-type: none">1. Nut and bolt missing2. Belt worn and/or stretched.	<ol style="list-style-type: none">1. Replace nut and bolt.2. Replace belt.
Engine does not start	<ol style="list-style-type: none">1. Power switch in OFF position.	<ol style="list-style-type: none">1. Place the power switch in the ON position.

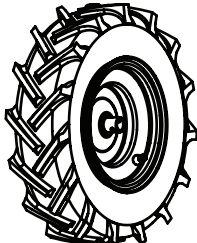
Component	Part Number and Description
	754-05069 Forward Belt, 4L x 25.4 754-04091 Reverse Belt, 3L x 29.125
	642-05032 RH Tine Assembly 742-05076 RH Tine 642-05033 LH Tine Assembly 742-05091 LH Tine
	746-05168 Neutral Cable 746-04413A Forward Cable 746-04414A Reverse Cable
	629-04157 Wire Harness
	634-04232 Tires, 13 x 5 x 6

Phone (800) 828-5500 to order replacement parts or a complete Parts Manual (have your full model number and serial number ready).
 Parts Manual downloads are also available free of charge at www.troybilt.com.

MANUFACTURER'S LIMITED WARRANTY FOR



The limited warranty set forth below is given by Troy-Bilt LLC with respect to new merchandise purchased and used in the United States and/or its territories and possessions, and by MTD Products Limited with respect to new merchandise purchased and used in Canada and/or its territories and possessions (either entity respectively, "Troy-Bilt").

This warranty is in addition to any applicable emissions warranty provided with your product.

"Troy-Bilt" warrants this product (excluding its *Belts*, *Transmission* and *Attachments* as described below) against defects in material and workmanship for a period of two (2) years commencing on the date of original purchase and will, at its option, repair or replace, free of charge, any part found to be defective in materials or workmanship. This limited warranty shall only apply if this product has been operated and maintained in accordance with the Operator's Manual furnished with the product, and has not been subject to misuse, abuse, commercial use, neglect, accident, improper maintenance, alteration, vandalism, theft, fire, water, or damage because of other peril or natural disaster. Damage resulting from the installation or use of any part, accessory or attachment not approved by Troy-Bilt for use with the product(s) covered by this manual will void your warranty as to any resulting damage.

Belts are warranted to be free from defects in material and workmanship for a period of thirty (30) days from the date of purchase.

Transmission — Troy-Bilt warrants the transmission (including all gears, shafts and housings) against defects in material and workmanship for the life of the tiller, to the original purchaser only, commencing on the date of original purchase or lease.

Attachments — Troy-Bilt warrants attachments for this product against defects in material and workmanship for a period of one (1) year, commencing on the date of the attachment's original purchase or lease. Attachments include, but are not limited to items such as: grass collectors and mulch kits.

HOW TO OBTAIN SERVICE: Warranty service is available, WITH PROOF OF PURCHASE, through your local authorized service dealer. To locate the dealer in your area:

In the U.S.A.

Check your Yellow Pages, or contact Troy-Bilt LLC at P.O. Box 361131, Cleveland, Ohio 44136-0019, or call 1-866-840-6483, 1-330-558-7220 or log on to our Web site at www.troybilt.com.

In Canada

Contact MTD Products Limited, Kitchener, ON N2G 4J1, or call 1-800-668-1238 or log on to our Web site at www.mtdcanada.com.

This limited warranty does **not** provide coverage in the following cases:

- a. The engine or component parts thereof. These items may carry a separate manufacturer's warranty. Refer to applicable manufacturer's warranty for terms and conditions.

- b. Log splitter pumps, valves, and cylinders have a separate one-year warranty.
- c. Routine maintenance items such as lubricants, filters, blade sharpening, tune-ups, brake adjustments, clutch adjustments, deck adjustments, and normal deterioration of the exterior finish due to use or exposure.
- d. Service completed by someone other than an authorized service dealer.
- e. Troy-Bilt does not extend any warranty for products sold or exported outside of the United States and/or Canada, and their respective possessions and territories, except those sold through Troy-Bilt's authorized channels of export distribution.
- f. Replacement parts that are not genuine Troy-Bilt parts.
- g. Transportation charges and service calls.
- h. Troy-Bilt does not warrant this product for commercial use.

No implied warranty, including any implied warranty of merchantability or fitness for a particular purpose, applies after the applicable period of express written warranty above as to the parts as identified. No other express warranty, whether written or oral, except as mentioned above, given by any person or entity, including a dealer or retailer, with respect to any product, shall bind Troy-Bilt. During the period of the warranty, the exclusive remedy is repair or replacement of the product as set forth above.

The provisions as set forth in this warranty provide the sole and exclusive remedy arising from the sale. Troy-Bilt shall not be liable for incidental or consequential loss or damage including, without limitation, expenses incurred for substitute or replacement lawn care services or for rental expenses to temporarily replace a warranted product.

Some states do not allow the exclusion or limitation of incidental or consequential damages, or limitations on how long an implied warranty lasts, so the above exclusions or limitations may not apply to you.

In no event shall recovery of any kind be greater than the amount of the purchase price of the product sold. **Alteration of safety features of the product shall void this warranty.** You assume the risk and liability for loss, damage, or injury to you and your property and/or to others and their property arising out of the misuse or inability to use the product.

This limited warranty shall not extend to anyone other than the original purchaser or to the person for whom it was purchased as a gift.

HOW STATE LAW RELATES TO THIS WARRANTY: This limited warranty gives you specific legal rights, and you may also have other rights which vary from state to state.

IMPORTANT: Owner must present Original Proof of Purchase to obtain warranty coverage.

Troy-Bilt LLC, P.O. BOX 361131 CLEVELAND, OHIO 44136-0019; Phone: 1-866-840-6483, 1-330-558-7220
MTD Canada Limited - KITCHENER, ON N2G 4J1; Phone 1-800-668-1238